ABSTRACT

In many DC-AC power conversions a voltage source inverter (VSI) along with an additional DC-DC boosting stage is required. To overcome this problem in VSI, a split source inverter is preferred. This paper presents a combination of boost stage and VSI stage as a single unit DC-AC power conversion named as split source inverter (SSI). The proposed topology require three additional diodes with same number of active switches of VSI and eight same states of conventional pulse width modulation. This work present the analysis of SSI with sinusoidal pulse width modulation technique. The developed SSI model is simulated on MATLAB/SIMULINK environment. Simulation results have been obtained for inverter voltage, inductor current, output line current and total harmonic distortion of output line current.

KEYWORDS: DC-AC, Split-source inverter, Voltage source inverter. Pulse width modulation. Total harmonic distortion.

INTRODUCTION

An inverter is basically a DC-AC power converter used in various power electronics system. This paper proposes a novel single unit DC-AC power converter called the split-source inverter (SSI) [1] as shown in figure 1. On the contrary with two unit conversion, the single unit DC-AC is becoming more popular due to its lower size, less weight and simplicity [2]-[4], [8]. This topology uses to reduce passive elements compared to the ZSI [5], in addition to have a diode for each inverter leg of SSI. The main advantages of SSI topology are continuous input current, constant inverter voltage with a low frequency component. In many electrical DC-AC power conversions, the AC output voltage is higher than the input voltage. If a voltage source inverter (VSI) is considered, then an additional DC-DC boosting stage is required to remove the step-down VSI limitations.[1], [6], [7], [8]. Many single unit DC-AC power converter topologies are reviewed in [9] and their modulation schemes are reviewed in [10]. This paper is structured as follows: analysis and modulation of the proposed three-phase SSI using SPWM technique. SPWM is the simplest popular control technology which is used widely in inverters [11]. Three sine waves displaced in 120 degree phase difference are used as reference signal for three phase inverter.

Three-phase split source inverter topology

A. Operation

In three phase SSI six semiconductor switches S1 to S6 are used as shown in figure 1. The lower switches are S4, S6, S2 and upper switches are S1, S3, S5. The operation is same as the conventional VSI inverter. In step I-S4, S6, S2 switches conducts, step II-S4, S6, S5 conducts, step III-S4, S3, S2 conducts, step IV-S4, S3, S5 conducts, step-V S1, S6, S2 step VI-S1, S6, S5 conducts, step VII- S1, S3, S2 conducts, step VIII- S1, S3, S5 conducts then the sequence are repeated from step I again. From step I to VII inductor is charge but at VIII step inductor totally discharge and charge the inverter DC link capacitor. In this three diode in each legs are used for boosting purpose.

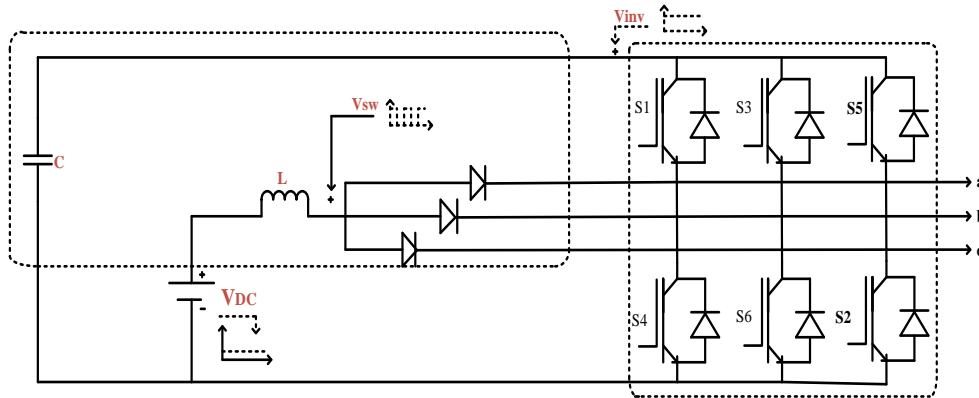

Figure 1. Proposed three-phase split source inverter (SSI)

B. Mathematical Derivation

D = duty cycle

$$D = \frac{t_{on}}{t_{on} + t_{off}} \quad (1)$$

ton = the inductor charging time during one switching cycle.

toff = the inductor discharging time during one switching cycle.

M= modulation index

Where D = M

$$D(\theta) = 0.5 - \frac{M}{2} \sin(\theta) \quad (2)$$

Average duty cycle Dav

$$D_{avg} = \frac{1}{2} + \frac{3\sqrt{3}M}{4\pi} \quad (3)$$

The normalized inverter and output fundamental peak phase voltage can be determined

$$\frac{V_{inv}}{V_{DC}} = \frac{4\pi}{2\pi - 3\sqrt{3}M} \quad (4)$$

Equation (4) multiplied by 2π

$$\frac{V_{\phi 1}}{V_{DC}} = \frac{2\pi M}{2\pi - 3\sqrt{3}M} \quad (5)$$

Inductor and Capacitance is given by

$$L \approx \frac{KMV_{inv}}{6\pi f_1 \Delta V_{inv}} + \frac{D_{max} V_{DC}}{2f_s \Delta I_L} \quad (6)$$

Put the value of K

$$L \approx \frac{3\sqrt{3}}{8\pi} \frac{MV_{inv}}{6\pi f_1 \Delta I_L} + \frac{D_{max} V_{DC}}{2f_s \Delta I_L} \quad (7)$$

$$C \approx \frac{KMI_{DC}}{6\pi f_1 \Delta V_{inv}} + \frac{(1-D_{min})I_{DC}}{2f_s \Delta V_{inv}} \quad (8)$$

$$C \approx \frac{3\sqrt{3}}{8\pi} \frac{KMI_{DC}}{6\pi f_1 \Delta V_{inv}} + \frac{(1-D_{min})I_{DC}}{2f_s \Delta V_{inv}} \quad (9)$$

K is constant given by

$$K = \frac{3\sqrt{3}}{8\pi} \quad (10)$$

$$\Delta I_L = \Delta I_{Ll} + \Delta I_{Lh} \quad (11)$$

$$\Delta V_{invl} = \Delta V_{invl} + \Delta V_{invh} \quad (12)$$

Dmin and Dmax are the minimum and maximum values of the duty cycle given by

$$D_{min} = \frac{1}{2} + \frac{1}{4}M \quad (13)$$

$$D_{min} = \frac{1}{2} + \frac{1}{4}M \quad (14)$$

SIMULATIONS RESULTS AND DISCUSSION

Firing pulses of inverter have been generated using sinusoidal PWM technique. The proposed model for firing pulses generation using SPWM as shown in figure 2 and the generated six firing pulses are shown in figure 3.

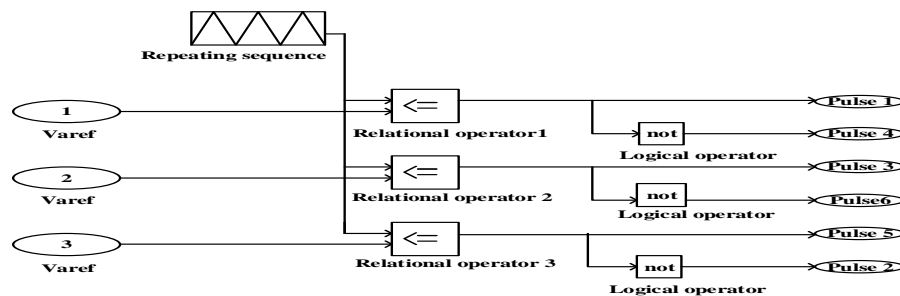

Figure2. Simulink model of SPWM

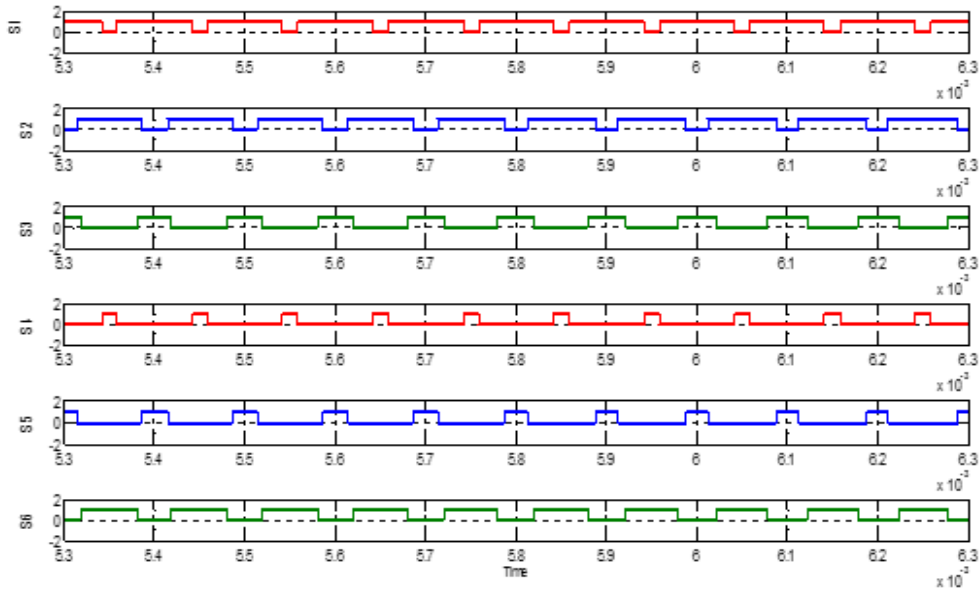

Figure 3. SPWM pulses

The design of inductor and capacitor have been done using (7) and (9) for desired current and voltage ripple. The parameter used for SSI are shown in table 1.

Table 1. Parameters of SSI SPWM

V_{DC}	I_{DC}	$V_{\phi 1}$	Pf	$I_{\phi 1}$	f_s	f_1	L_{filter}	C_{filter}	M	V_{in}	D		L	C
									M	(V)	D_{min}	D_{avg}	L (mH)	C (μF)
100	20A	$110\sqrt{2}$ V	0.8 lag	$7.58\sqrt{2}$ A	10.0KHz	50Hz	1.0mH	60.0 μF	.6804 (Eq. 5)	457 (Eq. 4)	.6701 .8402 (Eq. 13)	.7813 (Eq. 3)	15.3 (Eq. 6)	380 (Eq. 8)

Inverter Voltage

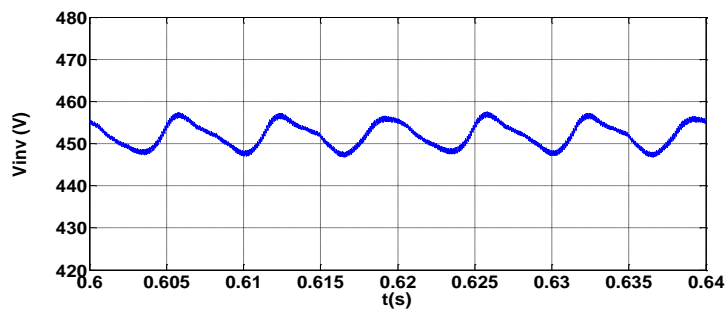

(a)

Inductor current

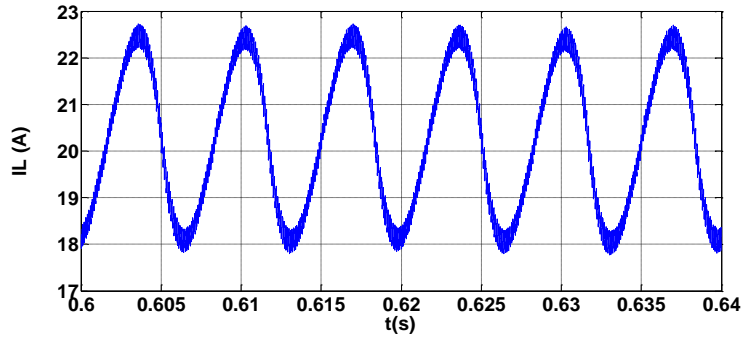

(b)

Output line current

The output line current waveform are shown in figure (c). The THD of output line current have been obtain for different load. It is observed that the THD for pure resistive load is minimum 8.92% for RL load is higher and further increase of value of inductance the THD increasing.

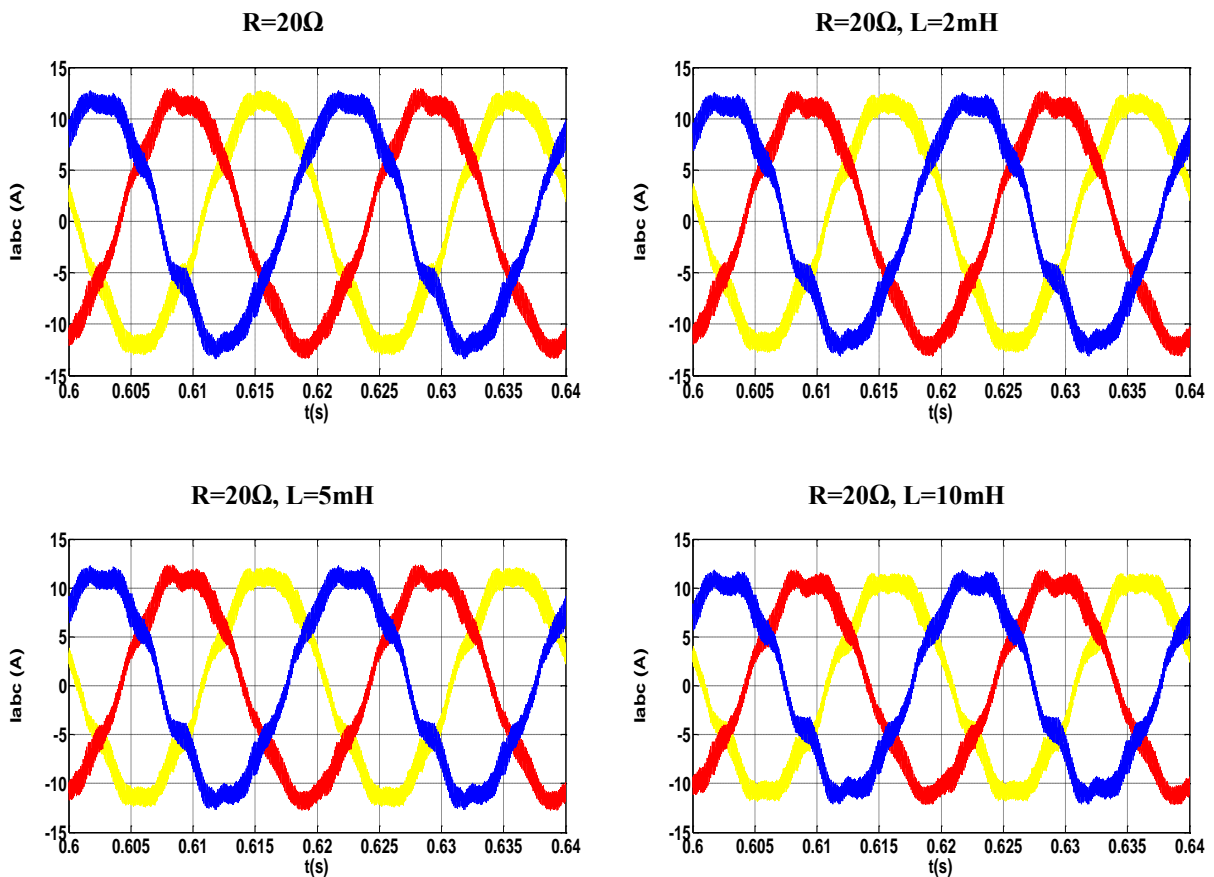

(c)

THD of output line current for various load

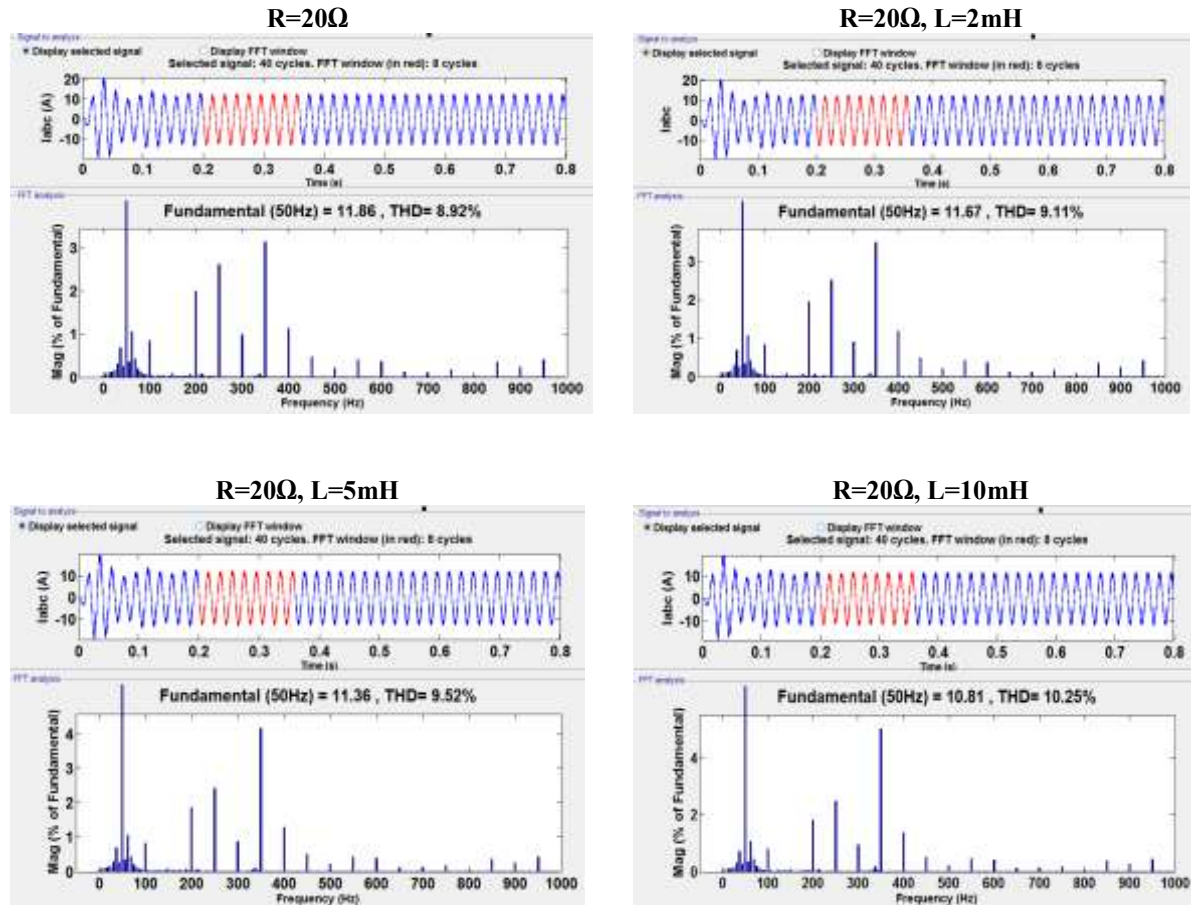

(d)

Figure 4. MATLAB/Simulink model results with sinusoidal modulation scheme (a) Inverter voltage (b) Inductor Current (c) Output line current for various load (d) Total harmonic distortion of output line current for various load.

CONCLUSION

This paper presents the design and analysis of three phase split source inverter as a single unit DC-AC power conversion. The proposed SSI have continuous input current, shorter commutation path, same eight switching states and same number of active switches as the VSI. In this work the sinusoidal pulse width modulation technique is implemented on SSI model. The developed SSI model is simulated using MATLAB/SIMULINK. Simulation results obtained for inverter voltage, inductor current and THD of output line current presents the better performance of SSI as compared to VSI and ZSI.

REFERENCES

- [1] Ahmed Abdelhakim, Paolo Mattavelli, Giorgio Spiazzi, "Three-phase Split-Source Inverter (SSI): Analysis and Modulation" IEEE Transaction on power Electronics, vol. 5, 2011.
- [2] M.-K. Nguyen, Y.-C. Lim, and S.-J. Park, "A comparison between single-phase quasi- z -source and quasi-switched boost inverters," Industrial Electronics, IEEE Transactions on, vol. 62, no. 10, pp. 6336–6344, Oct 2015.
- [3] M. Mohr, W. Franke, B. Wittig, and F. Fuchs, "Converter systems for fuel cells in the medium power range; a comparative study," IEEE Transactions on Industrial Electronics, vol. 57, no. 6, pp. 2024–2032, June 2010.

- [4] A.Hakeem, A. Elserougi, A. El Zawawi, S. Ahmed, and A. Massoud, "Amodified capacitor voltage control algorithm for suppressing the effect of measurement noise on grid-connected z-source inverters controllers," in Industrial Electronics Society, IECON 2013 - 39th Annual Conference of the IEEE, Nov 2013, pp. 204–209.
- [5] F.Z. Peng, "Z-source inverter," IEEE Transactions on Industry Applications. Vol. 39, no.2, pp. 504-510, march 2005.
- [6] R. Caceres and I. Barbi, "A boost dc-ac converter: analysis, design, and experimentation," IEEE Transactions on Power Electronics, vol. 14,no. 1, pp. 134–141, Jan 1999.
- [7] J. Alves, A. Perin, and I. Barbi, "An electronic ballast with high power factor for compact fluorescent lamps," in Industry Applications Conference, 1996. Thirty-First IAS Annual Meeting, IAS '96., Conference Record of the 1996 IEEE, vol. 4, Oct 1996, pp. 2129–2135 vol.4.
- [8] A. Abdelhakim, "Analysis and modulation of the buck-boost voltage source inverter (bbvsi) for lower voltage stresses," in Industrial Technology (ICIT), 2015 IEEE International Conference on, March 2015, pp. 926–934.
- [9] Y. Siwakoti, F. Z. Peng, F. Blaabjerg, P. C. Loh, and G. Town, "Impedance-source networks for electric power conversion part i: A topological review," IEEE Transactions on Power Electronics, vol. 30,no. 2, pp. 699–716, Feb 2015.
- [10] Y. Siwakoti, F. Z. Peng, F. Blaabjerg, P. C. Loh, G. Town, and S. Yang, "Impedance-source networks for electric power conversion part ii: Review of control and modulation techniques," IEEE Transactions on Power Electronics, vol. 30, no. 4, pp. 1887–1906, April 2015.
- [11] Chunyan, Zang, Zhenjiang, Pei, Junjia, He, Ting, Guo, Jing, Zhu, Wei, Sun. Research on the application of CPSSPWM technology in cascaded multilevel inverter. *International Conference on Electrical Machines and Systems*.2009: 1-4.